

NOTE:  
Berkeley had a habit of not including drawings of their fuselage formers on their plans. I have re-generated these formers using the Paul Matt 3-views and believe them to be reasonably accurate, however I have not built from these plans so be careful to check your formers against the plan and while building. It appears that all necessary information is in the plan to obtain parts patterns by cutting them from extra copies of the plan. Study the plan carefully to locate what you need. Good luck!

Rufus Carswell  
Atlanta, GA USA  
"Planeman"

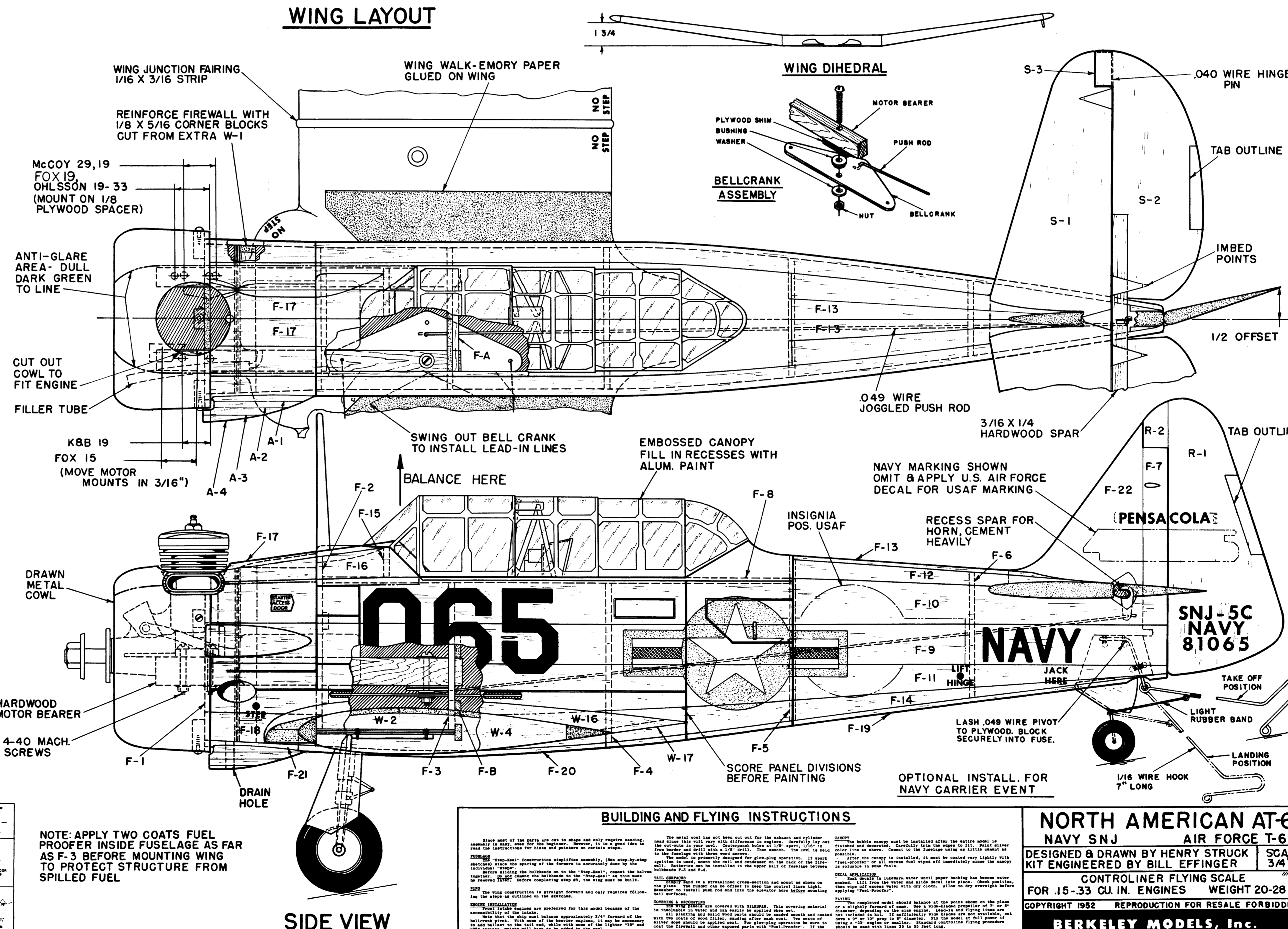
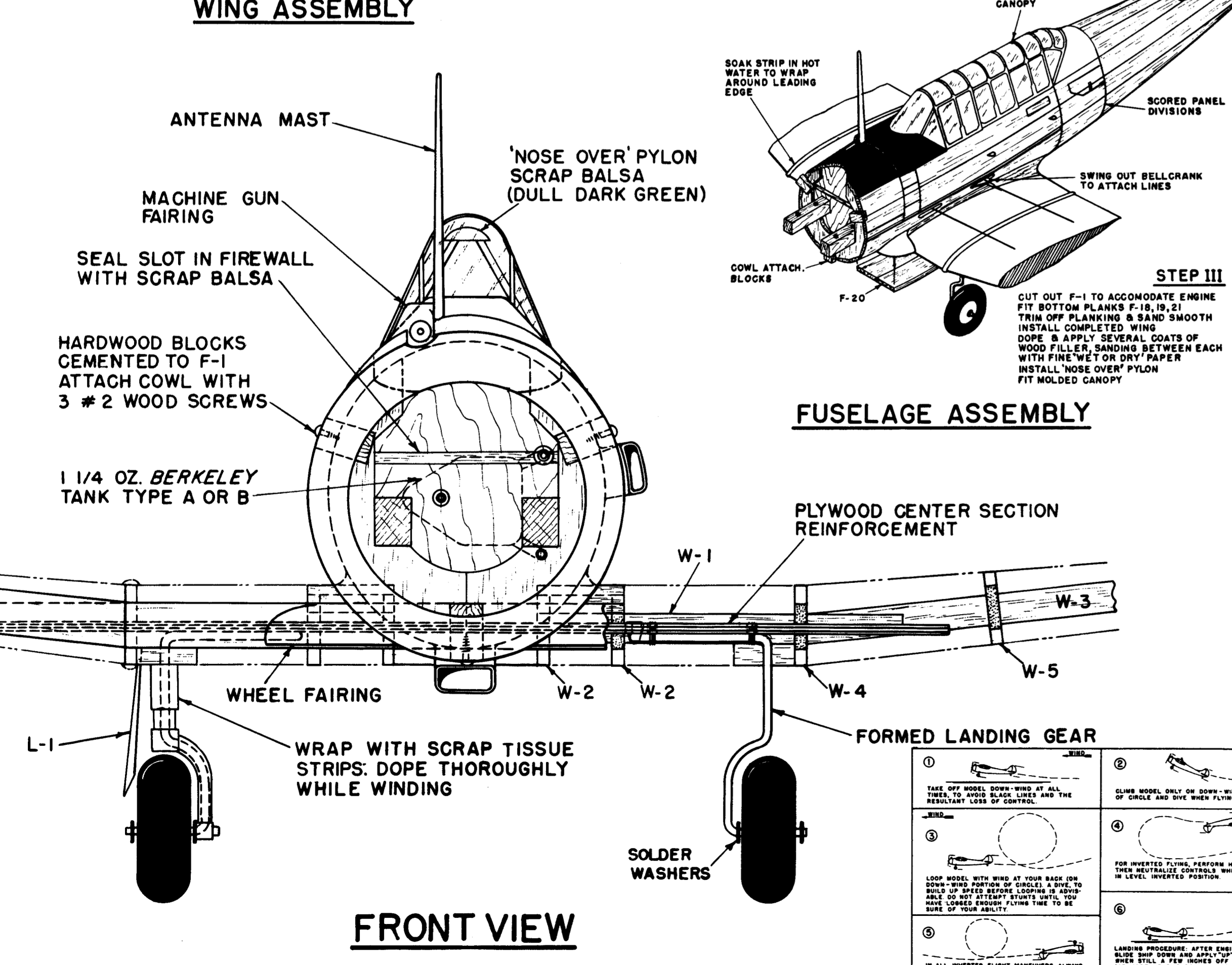
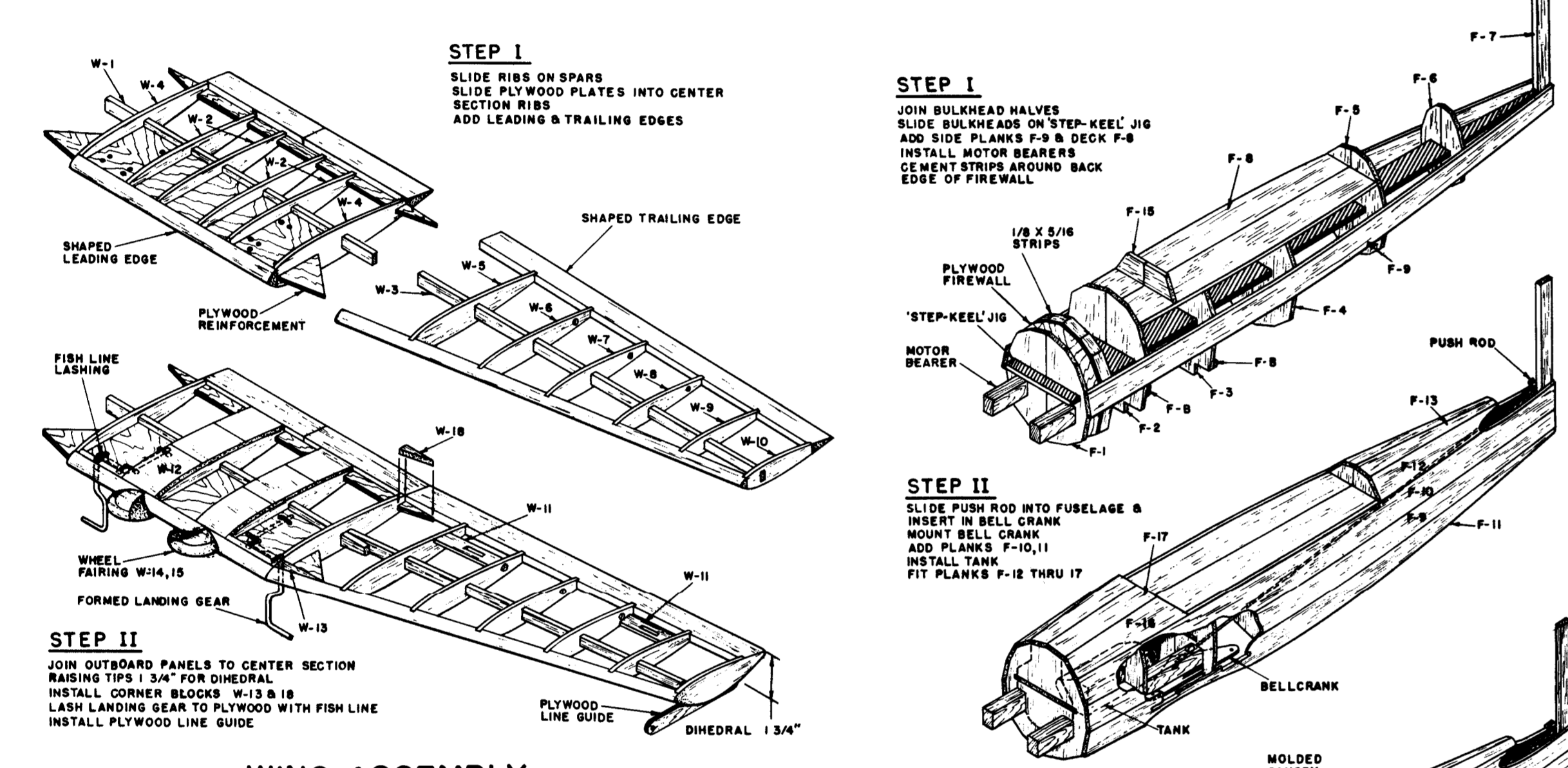
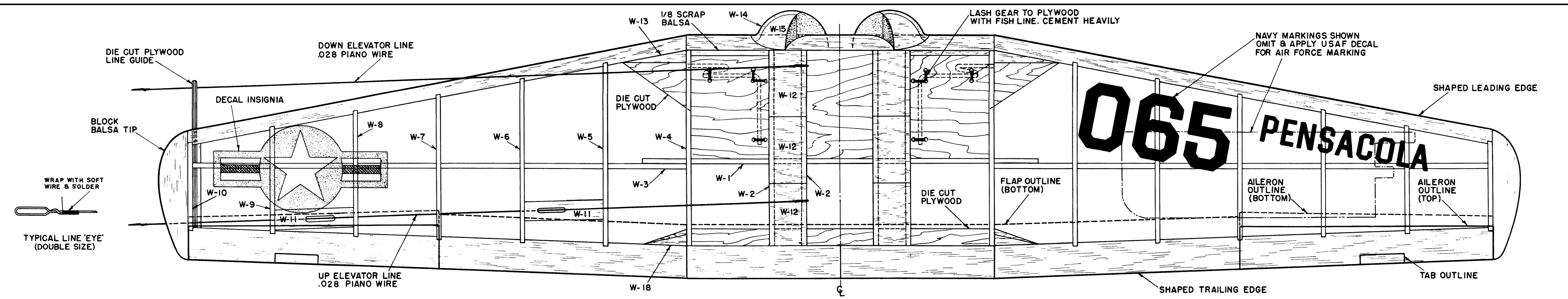

NOTE: APPLY TWO COATS FUEL PROOFER INSIDE FUSELAGE AS FAR AS F-3 BEFORE MOUNTING WING TO PROTECT STRUCTURE FROM SPILLED FUEL

### BUILDING AND FLYING INSTRUCTIONS

Start most of the parts are not to shape and only require sanding. Sanding is to be done with 220-grit sandpaper. Use a sanding block to sand the inside of the fuselage. Sand the motor, bellcrank, and landing gear. Use a file to smooth the landing gear. Use a sharp knife to trim the wings. Use a utility knife to cut the plywood. Use a soldering iron to solder the wire. Use a hot glue gun to glue the motor and bellcrank. Use a wood glue to glue the landing gear. Use a epoxy to glue the motor and bellcrank. Use a epoxy to glue the landing gear. Use a epoxy to glue the motor and bellcrank. Use a epoxy to glue the landing gear.

<b>NORTH AMERICAN AT-6</b>	
NAVY SNJ	AIR FORCE T-6
DESIGNED & DRAWN BY HENRY STRUCK	
KIT ENGINEERED BY BILL EFFINGER	
CONTROL LNER FLYING SCALE	
FOR .15-.33 CU. IN. ENGINES WEIGHT 20-28 OZ.	
COPYRIGHT 1982 REPRODUCTION FOR RESALE FORBIDDEN	
<b>BERKELEY MODELS, Inc.</b>	
FORT SMITH, ARKANSAS U.S.A.	

