

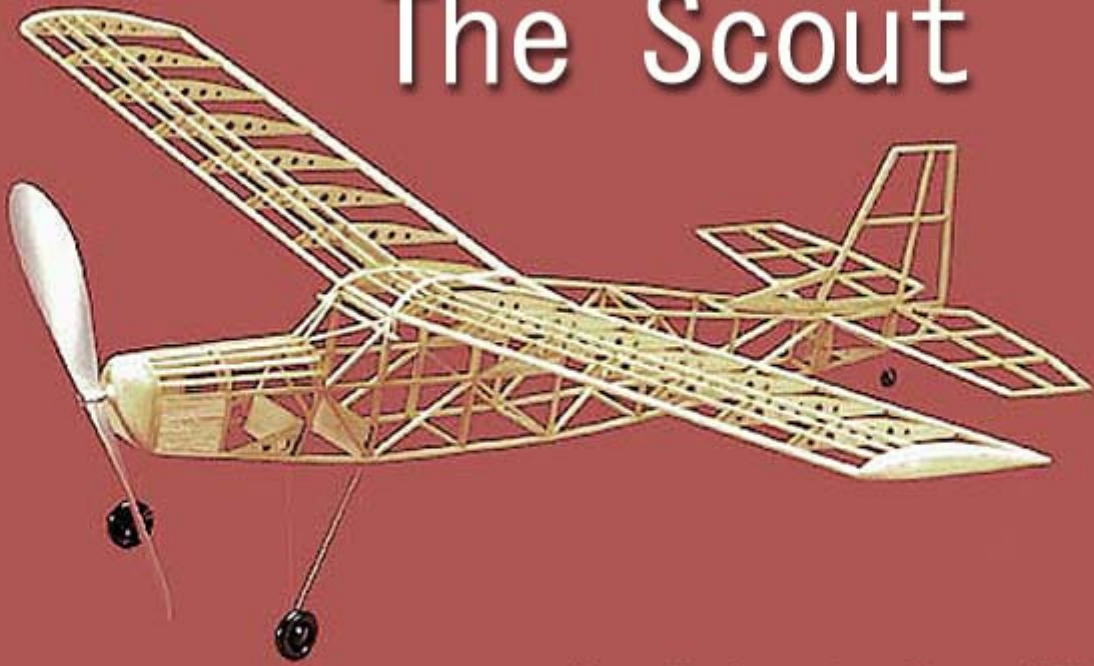

# The Scout



Herr Engineering Corp. HRR101



## ASSEMBLY INSTRUCTIONS

**CONGRATULATIONS:** You are now the proud owner of one of the finest model airplane kits ever produced. The laser cut parts eliminate the tedious chore of cutting printwood or salvaging die-crushed parts. Because the laser cuts the parts so perfectly, small lands or uncut sections have been left to hold the parts in the sheets. This allows the cut sheets to be handled. Otherwise the parts would fall from the sheet every time it is picked up. To remove the parts from the sheet, use your X-acto knife or a single edge razor blade. Then sand the edge of the part as required.

You will need the following tools and supplies to build this model:

<b>Building Board</b>	18" x 30" flat smooth board soft enough to press pins into.
<b>Wax Paper</b>	To protect the plan during building.
<b>X-Acto Knife</b>	With a #11 blade.
<b>Single Edge Razor Blade</b>	For precise cutting of small parts.
<b>Straight Pins</b>	Use to pin parts to building board during construction.
<b>Sandpaper</b>	Several small pieces of 220 grit sandpaper. Glue some to a small block of wood making a convenient sanding block.
<b>Needle Nose Pliers</b>	Small pair for bending and cutting wire parts.
<b>Glue</b>	Traditional modeling cement is preferred, such as Ambroid or Duco cement. C/A (Super Glue) may also be used to construct this model. You will also need a small amount of epoxy to secure the wheel retaining thread.
<b>Drill Bits</b>	You will need the following sizes of drill bits to complete this model- 1/4", 3/16", and 1/8" diameter.
<b>Clear Low Shrink Dope</b>	You will need several ounces of clear dope to attach the tissue to the model and to finish the model. We prefer using Nitrate dope but Butyrate dope may also be used. You will also need thinner.
<b>Paint Brushes</b>	Two small brushes, one about 1/4" wide and one about 1" wide will be adequate to finish this model.
<b>Pump Spray Bottle</b>	Used to lightly spray the model with alcohol to shrink the tissue.
<b>Rubbing Alchole</b>	Used to shrink the tissue.

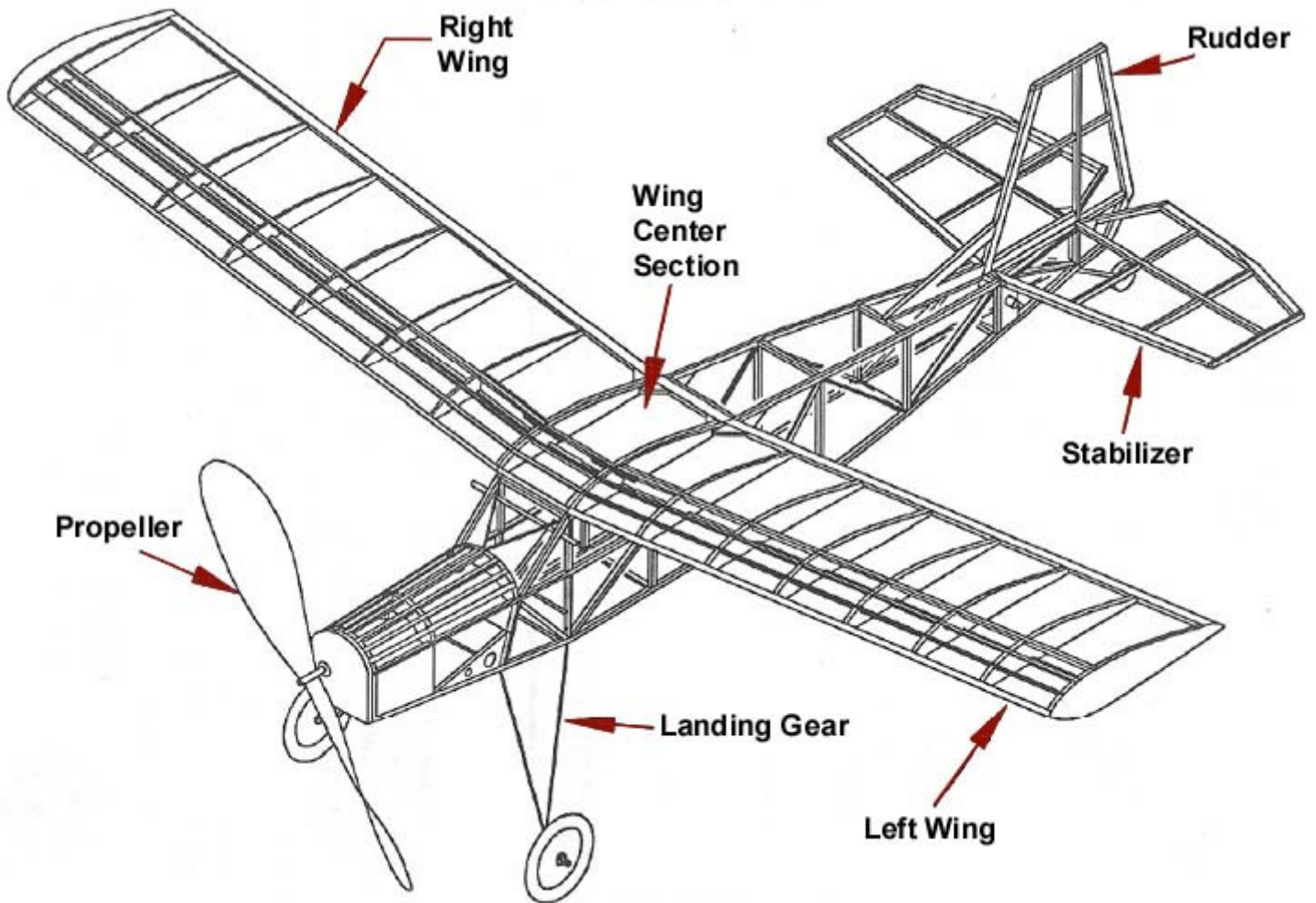

## Building the Tail Surfaces

1. Cover the plan with wax paper for protection.
2. Cut the balsa pieces for the outline of the parts and pin in position on the plan. Glue the adjoining parts as you go.
3. Cut the stripwood pieces for the interior framework and glue into position.
4. Glue laser cut parts into position.
5. Carefully pull out the pins using a twisting motion and remove the parts from the plans. Sand the parts smooth and round the leading edges, trailing edges and the tips.
6. Set these parts aside until it's time to cover the model.

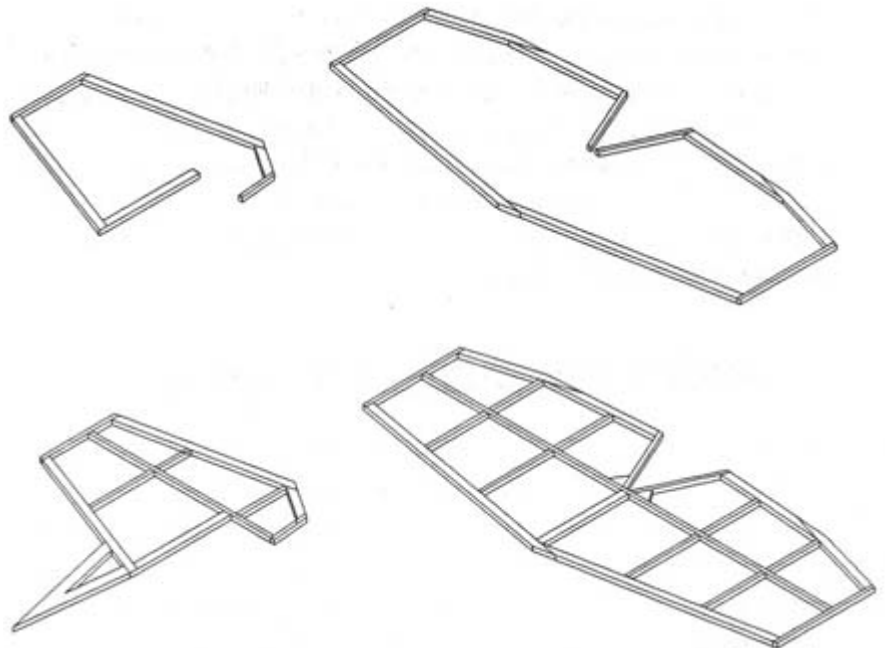

## Building the Fuselage

1. Cover the fuselage plan with wax paper.
2. Build the side frames (ONE AT A TIME) over the plan from stripwood and laser cut pieces.
3. Cut the 16 cross pieces for the fuselage. Measure from the bottom view on the plan. Leave the cross pieces on the plan near the bottom view so you do not mix them up.
4. Pin the side frames over the bottom view on the plan. Align the bottom longeron with the plan in the cabin area. Glue the 6 cross pieces and then the 4 doublers into position in the cabin area.
5. Pull the tail together and glue together making sure the tail post is 90 degrees to the building and is straight and aligned with the rest of the fuselage.
6. Glue the rear cross pieces to the fuselage. Glue F-10 into the bottom of the fuselage at the tail.
7. Pull the nose together and glue F-5 into position. Use care to make sure the front of the fuselage is straight and square.
8. Glue F-6, F-7, F-8 and F-9 to the fuselage in the positions shown on the plan. Glue the balsa stringers into position in the nose formers.
9. Laminate the forward landing gear mount from the 3 laser cut pieces. Do not glue F-13 in place now.
10. Glue the forward landing gear mount into the fuselage and then sand the bottom flush if required.
11. Repeat the previous steps to laminate and install the rear landing gear mount.
12. Assemble the nose block from the 4 laser cut pieces. Carve and sand the nose block to the shape shown on the plan. Drill the 1/4" hole for the prop bushing. Be careful to drill this hole with the proper amount of down thrust and right thrust.

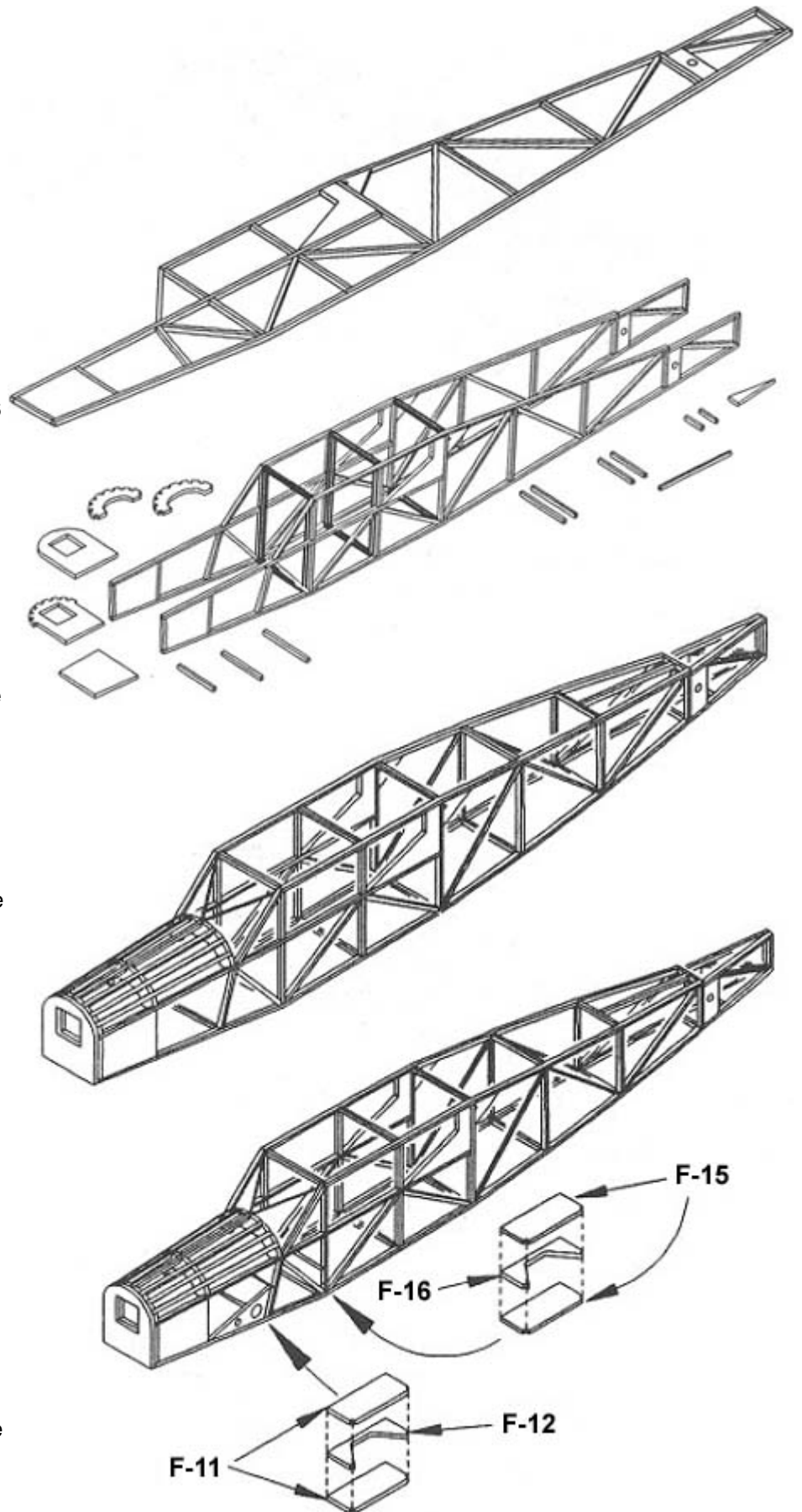

13. Bend and assemble the landing gear on the model. Do not glue the landing gear to the model until after covering. After assembly, remove the landing gear from the model until after covering.
14. Cut and glue the diagonal windshield braces into place. Cut and test fit the windshield and side windows. Set them aside until after covering.
15. Sand the fuselage smooth and set it aside until it is time to cover the model.

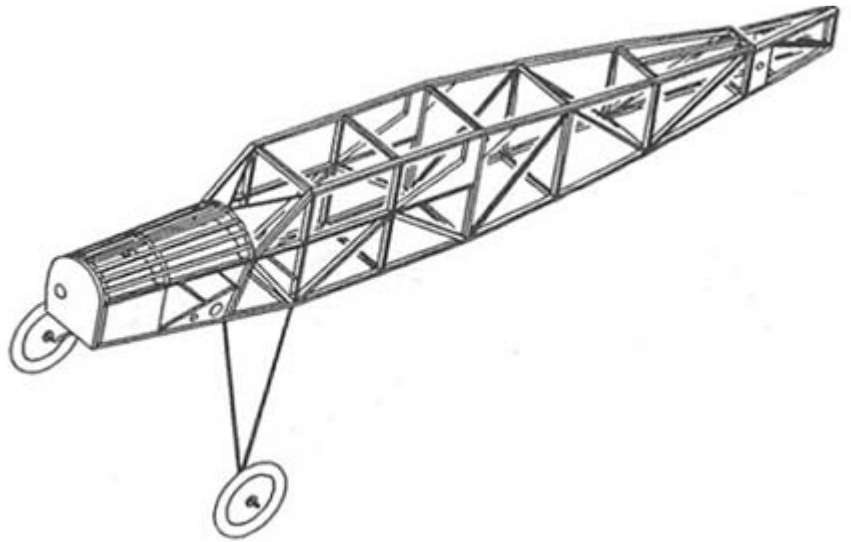

## Building the Right and Left Wings

1. Cover the plan with wax paper.
2. Pin the lower spar for the right wing to the plan.
3. Glue part "D" to the rear of the spar 3/32" in from the inboard end.
4. Pin the trailing edge into position on the plan.
5. Glue one RIB-2 into position at the inboard end of the wing. This rib should be glued to the lower spar, the trailing edge and also the end of part "D".
6. Position the remaining ribs in position holding them 90 degrees to the building board and glue them in place.
7. Glue the top spar into place.
8. Glue the leading edge and the leading edge spars in place.
9. Remove the wing from the building board and sand smooth all over.
10. Sand and carve the wing tip to shape. Glue it to the end of the wing and then sand even with the wing.
11. Set the right wing aside until it is time to join the wings.
12. Build the left wing over the plan as you did the right wing.
13. Set the left wing aside until needed for joining.

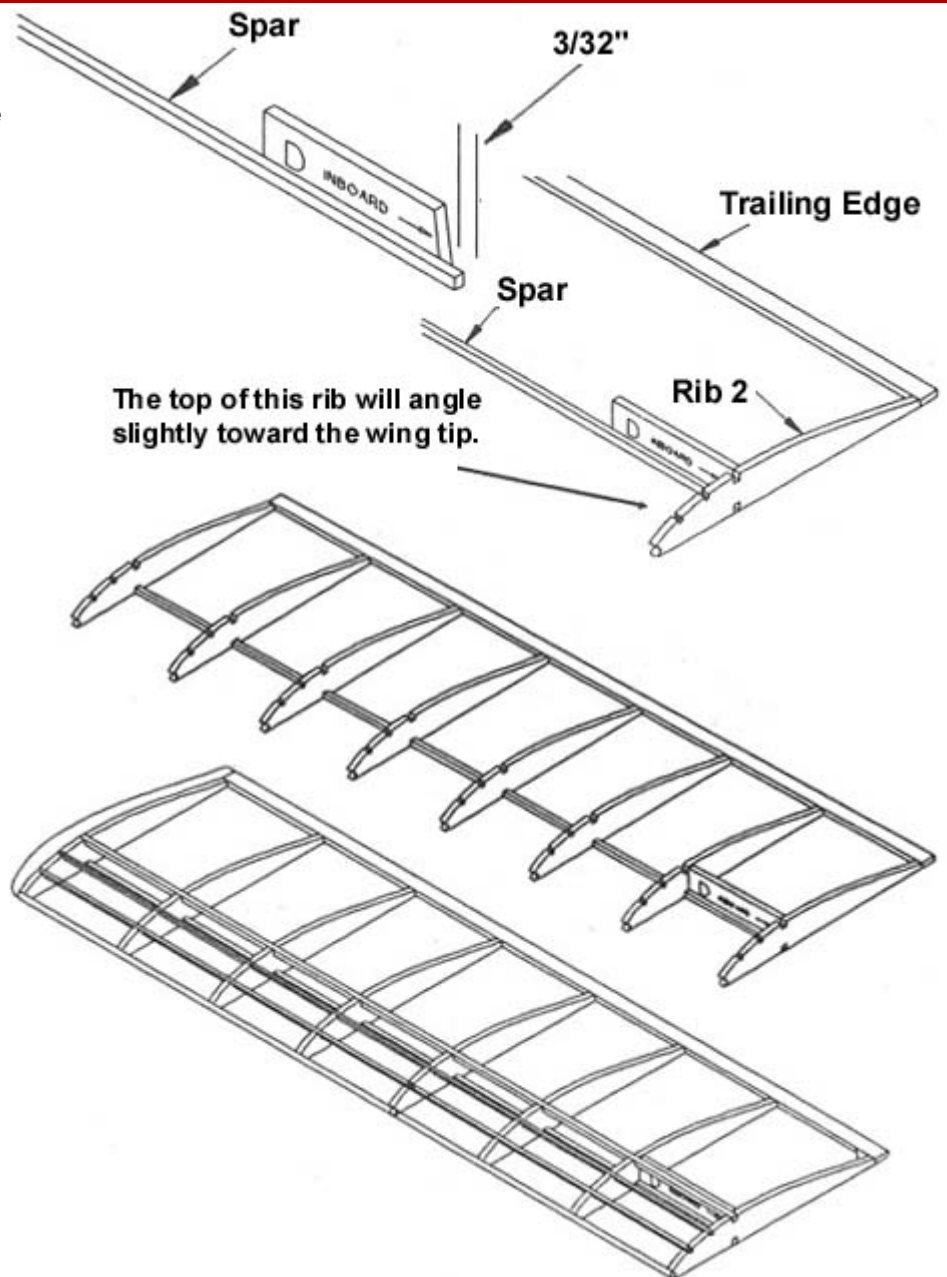

## Building the Center Section

1. Cover the plan with wax paper.
2. Pin the bottom spar in position on the plan.
3. Pin the trailing edge in position.
4. Glue the two RIB-1's in place. Be sure to align the ribs with the plan and make sure the ribs are 90 degrees to the building board. Glue gussets "T" in place.
5. Glue the top spar, leading edge and leading edge spars into position.
6. Remove the center section from the plan and sand it smooth.

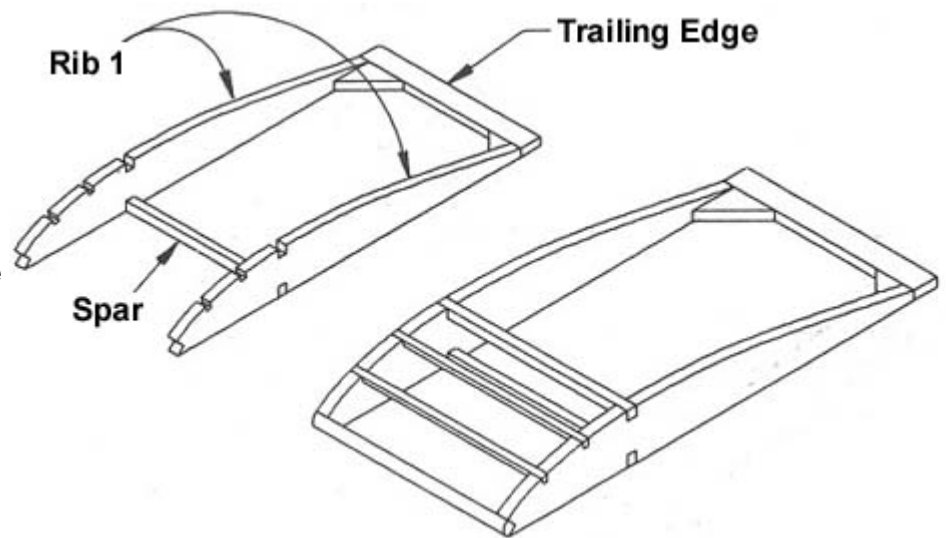

## Joining the Wings

1. Cover the plan with wax paper.
2. Pin the center section into position over the plan.
3. Fit the right wing to the center section. Support the tip to achieve the desired dihedral angle.
4. When satisfied with the fit, butt glue the right wing to the center section. Pin the right wing to the center section and support the tip until the glue dries.
5. Cut 1/16" wide slots in ribs at the dihedral joint. These slots are immediately in front of the spars (top and bottom) and are just as deep as the spar.
6. Glue two plywood dihedral braces into the slots ahead of the top and bottom spars.
7. Join the left wing to the center section as you did the right.
8. When the glue is dry, remove the completed wing from the building board and sand smooth.

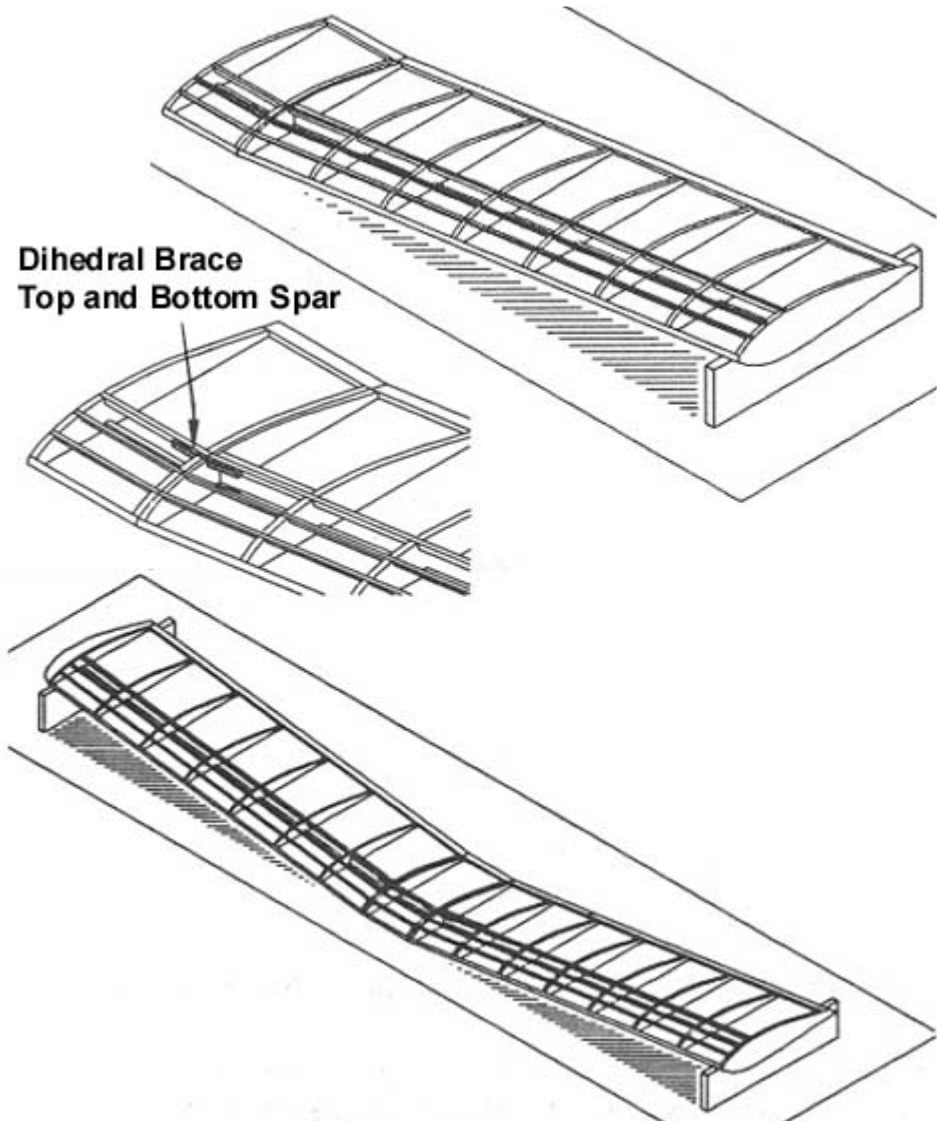

## Cover the Parts with Tissue

---

Cover the models balsa framework with tissue attached with clear dope.

1. First apply two coats of un-thinned dope to the structure where the tissue will touch. Lightly sand after the first coat.
2. Cut pieces of tissue about 1" larger all around than the part being covered.
3. Attach tissue to the part with clear dope thinned 50-50 with thinner.
4. After all parts are covered, lightly spray them with rubbing alcohol to shrink the tissue. Be careful to not allow the parts to warp or twist while they dry.
5. After covering, apply two coats of dope thinned 50-50 with thinner to the entire model to seal and protect the tissue. Add a small amount of retarder to the dope to increase the drying time.

## Final Assembly

---

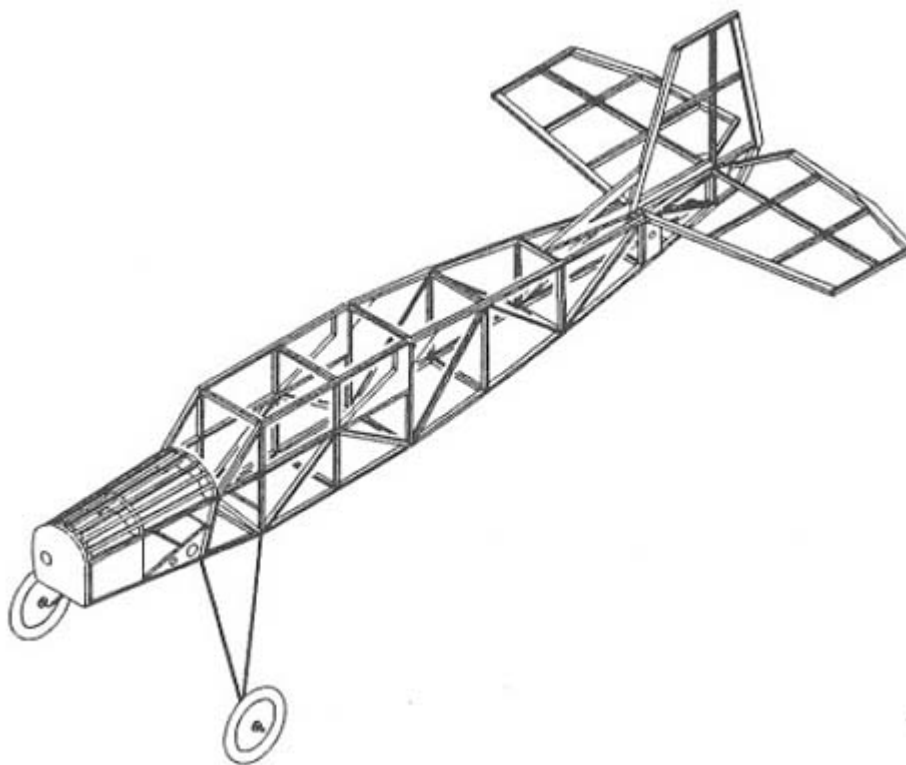
1. Carefully glue the windshield and side windows into place.
  2. Carefully drill windshield for the forward wing hold down dowel. The point of a sharp #11 X-acto knife works well.
  3. Glue the front and rear wing hold down dowels in place.
  4. Attach the wing to the fuselage with rubber bands.
  5. Position the stabilizer on the rear of the fuselage. Adjust the fit as necessary to align the stabilizer with the wing. When properly positioned, the stabilizer should be glued into position.
  6. Glue the rudder to the fuselage keeping it 90 degrees to the stabilizer until the glue dries.
- 
7. Glue the landing gear and balsa fillers into the landing gear mounts. Sand the fillers flush and cover with a small strip of tissue. Roughen the axles at the end with sandpaper and secure the wheels with thread and epoxy. Epoxy the tail wheel assembly to the bottom of the fuselage in the position shown on the plan.
  8. Assemble the prop, prop shaft and thrust washers as shown on the plan. Glue the prop bearing into the nose block with epoxy.
  9. Tie a square knot to join the two ends of the rubber motor.
  10. Loop the motor to make a 4 strand loop approximately 21" long. Install the motor in the model. The rear of the motor is retained by the piece of aluminum tube. The forward end is attached to the hook on the prop shaft. The removable nose block should be a tight fit on the front of the model to prevent it from coming loose in flight.
  11. Attach the wing to the model with the rubber bands.

12. Carefully check the model for warps or twists to make sure all of the flying surfaces are straight and true.
13. Balance the model at the location shown on the plan. Add modeling clay as required to the nose or rear fuselage to achieve this balance.
14. Your model is now complete. You Must read all of the safety instructions and obey them when you fly your model.

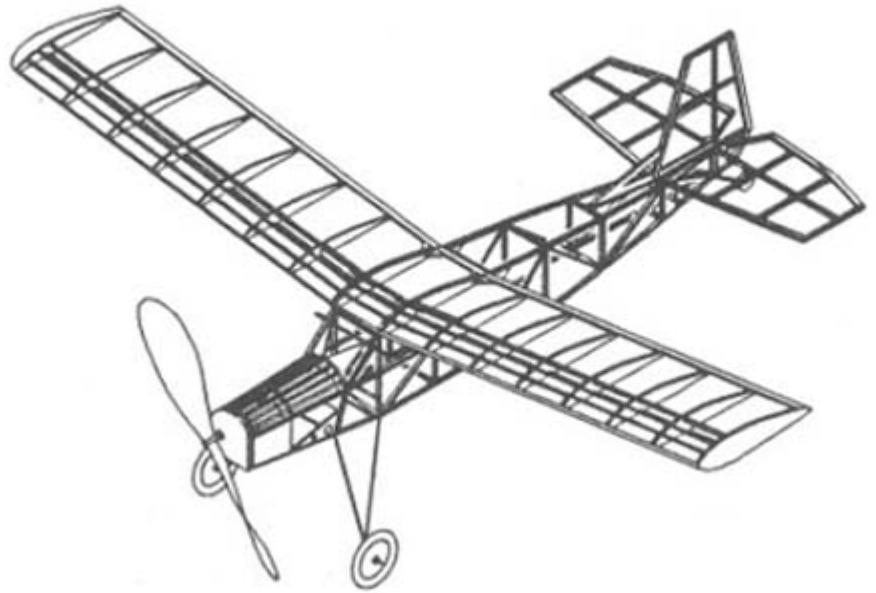

## Your First Flights

1. Wind the motor about 100 turns.
2. Point the nose of the model into any gentle breeze that may be blowing.
3. Release the propeller and after it starts turning gently toss the model aiming the nose at a point on the ground 100' in front of you. Adjust the model to circle while gradually increasing the number of turns in the motor.
4. A properly trimmed model will circle to the left while climbing under power, level out as the power runs down and transitions into a right hand circling glide.

### Safety Rules

1. Fly your model in a large open area that is free of obstructions, people or their property.
2. Do not fly your model in the vicinity of power lines, trees, streets or buildings.
3. Never try to retrieve any model stuck in power lines, in trees or on a roof or other high place.
4. Position yourself at least 150' from spectators before launching model.
5. Never launch model directly at another person or other object.
6. Never stick your fingers into a spinning propeller. Do not try to stop a spinning propeller with your hand or fingers. Never stick any object into a spinning propeller.
7. Fly your model only on calm days. Do not fly when the wind is blowing.
8. Get proper permission before retrieving your model from private property.

### WARRANTY

Herr Engineering Corp. guarantees this kit to be free from defects in both materials and workmanship at the time of purchase. This warranty does not cover any component damaged buy use or modification. In no case shall Herr Engineering Corporation's liability exceed the original cost of the purchased kit. Further Herr Engineering Corp. reserves the right to change or modify this warranty without notice.

In that Herr Engineering Corporation has no control over the assembly or use, no liability shall be assumed or accepted for any damage resulting from the use by the user during construction of the kit or the use of the final user assembled product. By the act of building this kit and/or using the final user assembled product, the user accepts all liability.

If the buyer and/or user is not prepared to accept all of the liability associated with this product, he is advised to immediately return this kit in new and unused condition to the place of purchase for a full refund.

© Copyright SIG Mfg. Co., Inc.

**SIG MFG. CO., INC.....Montezuma, Iowa 50171-0520**

### LIMIT OF LIABILITY:

In use of our products, Sig Mfg. Co.'s only obligation shall be to replace such quantity of the product proven to be defective. User shall determine the suitability of the product for his or her intended use and shall assume all risk and liability in connection therewith.